



■ HWE

MC Precision Power Vise	1
MC Precision Power Vise Longer Type	3
MC Precision Power Vise (Optional Accessory)	4

■ HWA

Hydraulic Machine Vise	8
------------------------	---

■ HWC

Combined Hydraulic Machine Vise	10
---------------------------------	----

■ HWB

Tiltable Two-Way Hydraulic Machine Vise	11
-----------------------------------------	----

■ HWD

NC Hydraulic Machine Vise	13
Hydraulic Machine Vise (Optional Accessory)	15

■ HWY-A

Hydraulic & Angle Lock Vise	16
-----------------------------	----

■ HWE-AMV

Auto Vise	18
-----------	----



Interchangeable Jaw design. Various jigs for many uses can be installed on Vise. Jaw is made of Alloy Steel and its hardness is HRC52-56.

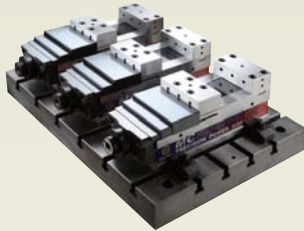

The tolerance of matched height is within $\pm 0.01\text{mm}$. Can combine many sets together for simultaneous processing to improve production efficiency.



Base with U-shape design enhances structure rigidity and reduces distortion. Rigid material Vise body is made of ductile iron FCD65. High tensile strength and no distortion.

Powerful down thrust Leaf-Spring mechanism eliminates workpiece lifting.



The parallelism and squareness of slots beneath vise base are very precise. Vise can be quickly positioned and fixed on the machining tables.



Short body with large Jaw-Opening is suitable for large & small machine center.

Both slideways flame hardened to HRC50~56 can resist wear and maintain accuracy for long.

Easy and quick adjustment of 5 different clamping forces.

Mechanical Pressure Booster system enhances efficiency and eliminates losing power.

An enlarged double thread master screw rod could make Movable Jaw move forward and backward fast. High rigidity.

Accuracy Inspection

	Inspection Items	Tolerance
1	<p>Parallelism : slideways to Vise bed</p>	0.01/100mm
2	<p>Squareness : between slideways and fixed jaw</p>	0.01/100mm
3	<p>Workpiece Lifting</p>	0.02mm
4	<p>H : Height of the body</p>	$\pm 0.01\text{mm}$
5	<p>L : Length between fixed jaw and slot</p>	$\pm 0.015\text{mm}$

HWE-MPV125 / 160 / 200

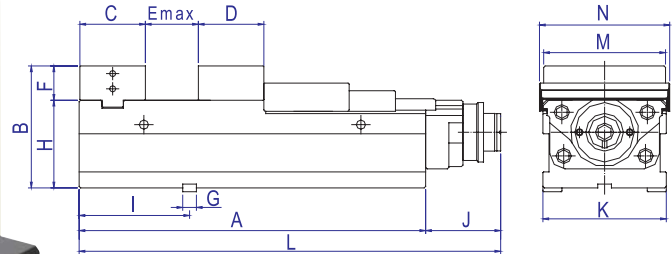
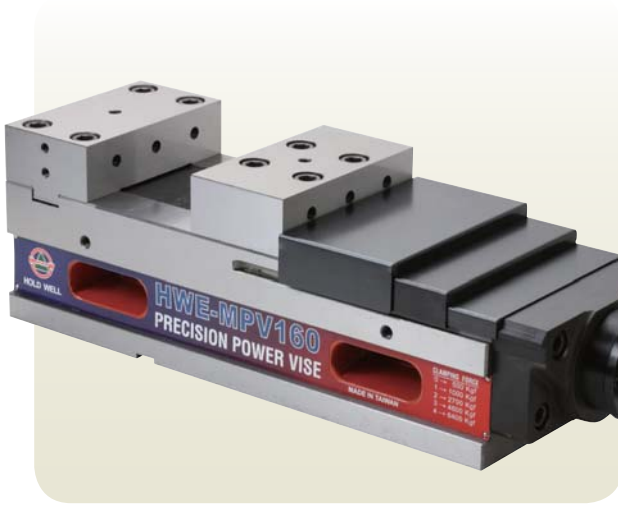

Model NO.	A	B	C	D	E max	F	G	H	I	J	K	L	M	N	N.W.(kg)
HWE-MPV125	365	145	78	74	205	45	18	100	145	98.5	126	463.5	125	135	35
HWE-MPV160	455	160	86	86	275	45	18	115	145	98.5	162	553.5	160	171	59
HWE-MPV200	505	180	100	97	300	55	18	125	177	98.5	202	603.5	200	211	90

Unit : mm



Clamping Force Setter

Clamping Force Table

Model NO. / Setting	0	1	2	3	4
HWE-MPV125	500	1600	2800	3600	4500
HWE-MPV160	500	1800	3200	4600	6000
HWE-MPV200	500	2200	3800	5500	7000

Unit : kgf

Standard Accessory



Eye Bolts



Wrench



Slide Cover



Positioning Block



Clamps

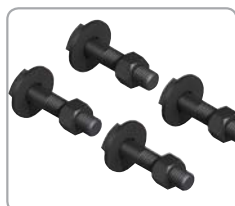

T-Nut & Screw



Handle Set

HWE-MPV160L / 200L

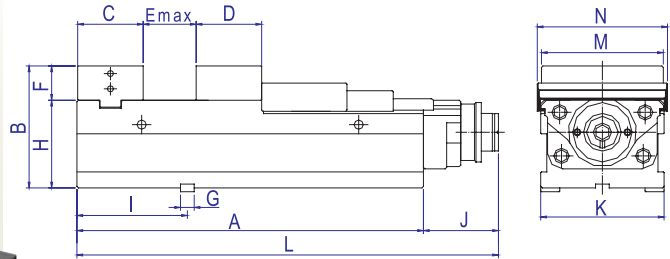
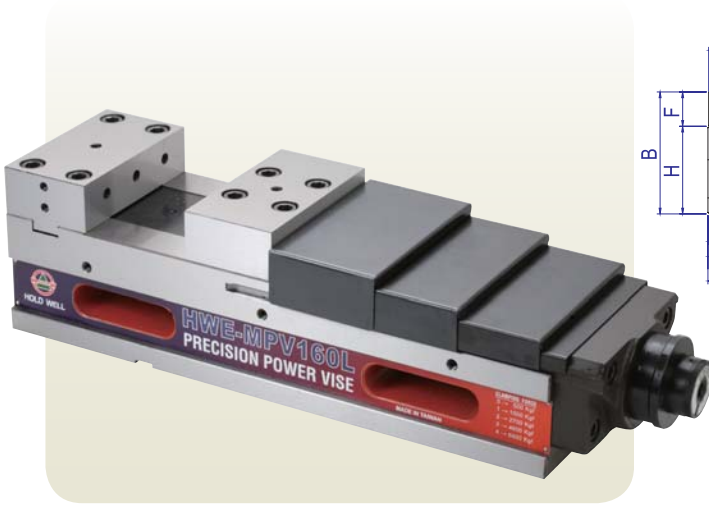

Model NO.	A	B	C	D	E max	F	G	H	I	J	K	L	M	N	N.W.(kg)
HWE-MPV160L	535	160	86	86	355	45	18	115	145	98.5	162	633.5	160	174	66
HEW-MPV200L	610	180	100	97	405	55	18	125	177	98.5	202	708.5	200	214	103

Unit : mm

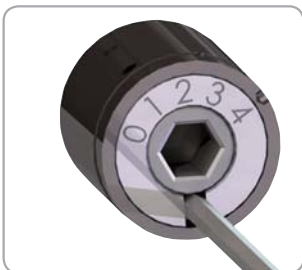

Clamping Force Setter

Clamping Force Table

Model NO. / Setting	0	1	2	3	4
HWE-MPV160L	500	1800	3200	4600	6000
HWE-MPV200L	500	2200	3800	5500	7000

Unit : kgf

Standard Accessory



Eye Bolts



Wrench

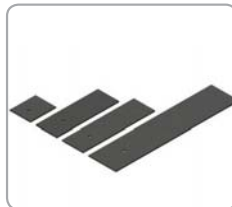

Slide Cover



Positioning Block



Clamps

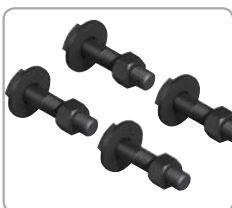

T-Nut & Screw



Handle Set



Standard Fixed Jaw MPV125 / 160/200-FJ

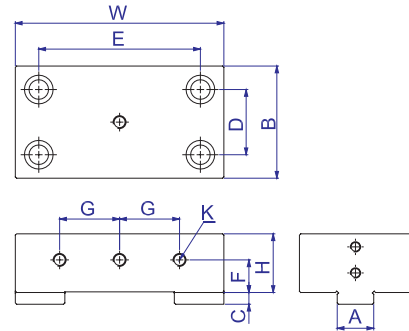

Model NO.	A	B	C	D	E	F	G	H	K	W
MPV125-FJ	24	76	8	45	88	25	32	45	M8	125
MPV160-FJ	28	86	9	50	124	25	46	45	M10	160
MPV200-FJ	28	98	9	62	140	27.5	50	55	M10	200

Unit : mm

Standard Movable Jaw MPV125 / 160 / 200-MJ

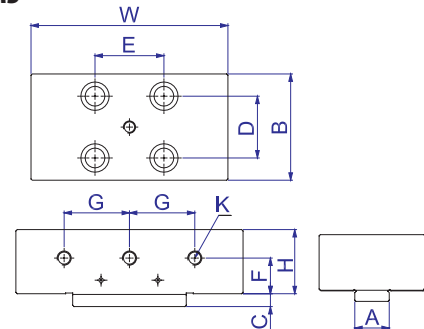
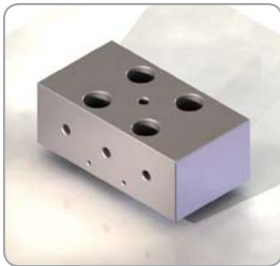

Model NO.	A	B	C	D	E	F	G	H	K	W
MPV125-MJ	24	76	8	45	88	25	32	45	M8	125
MPV160-MJ	28	86	9	50	124	25	46	45	M10	160
MPV200-MJ	28	98	9	62	140	27.5	50	55	M10	200

Unit : mm

Heightened Fixed Jaw MPV160 / 200-FHJ

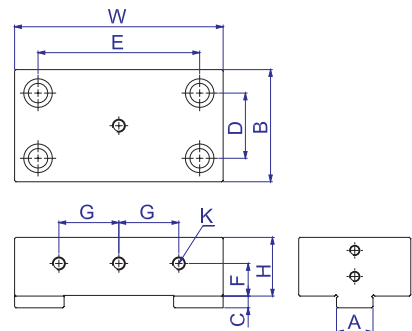
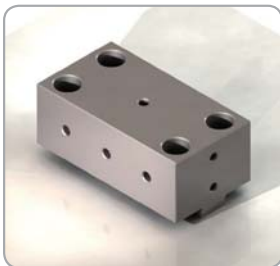

Model NO.	A	B	C	D	E	F	G	H	K	W
MPV160-FHJ	28	86	9	50	124	30	46	60	M10	160
MPV200-FHJ	28	98	9	62	140	35	50	70	M10	200

Unit : mm



Heightened Movable Jaw MPV160 / 200-MHJ

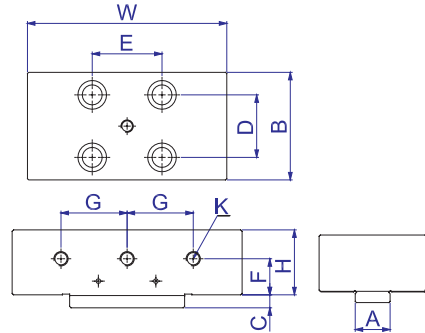
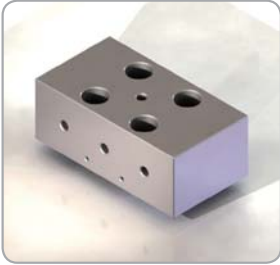

Model NO.	A	B	C	D	E	F	G	H	K	W
MPV160-MHJ	28	86	9	50	124	30	46	60	M10	160
MPV200-MHJ	28	98	9	62	140	35	50	70	M10	200

Unit : mm

L-Type Fixed Jaw MPV125 / 160 / 200-FLJ

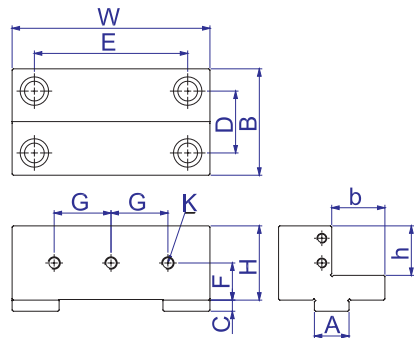

Model NO.	A	B	C	D	E	F	G	H	K	W	b	h
MPV125-FLJ	24	76	8	45	88	25	32	50	M8	125	38	32
MPV160-FLJ	28	86	9	50	124	30	46	60	M10	160	43	40
MPV200-FLJ	28	98	9	62	140	35	50	70	M10	200	49	45

Unit : mm

L-Type Movable Jaw MPV125 / 160 / 200-MLJ

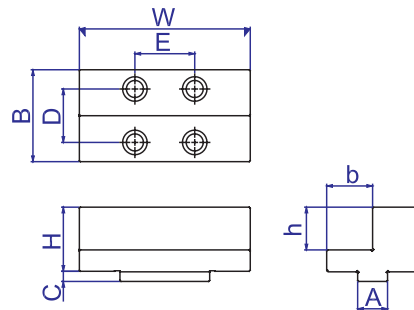

Model NO.	A	B	C	D	E	F	G	H	K	W	b	h
MPV125-MLJ	24	76	8	45	88	25	32	50	M8	125	38	32
MPV160-MLJ	28	86	9	50	124	30	46	60	M10	160	43	40
MPV200-MLJ	28	98	9	62	140	35	50	70	M10	200	49	45

Unit : mm



Inner Jaw MPV125 / 160 / 200-IGJ / IGHJ

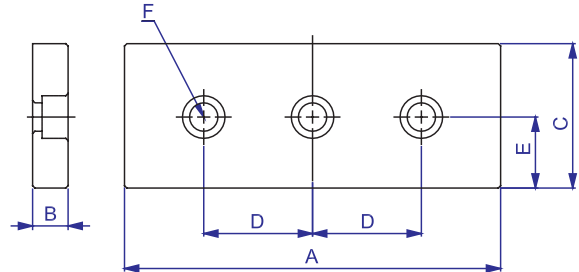
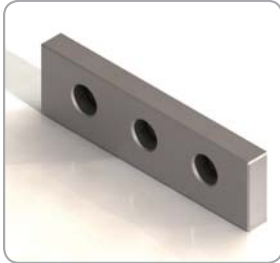

Model NO.	A	B	C	D	E	F (Bolt Size)
MPV125-IGJ	124	13	46	32	25	M8
MPV160-IGJ	159	15	46	46	25	M10
MPV200-IGJ	199	15	56	50	27.5	M10
MPV160-IGHJ	159	15	61	46	30	M10
MPV200-IGHJ	199	15	71	50	35	M10

※ MPV160-IGHJ & MPV200-IGHJ are only applied to Heightened Fixed Jaw & Heightened Movable Jaw

Unit : mm

Outer Jaw MPV 125 / 160 / 200-OGJ / OGHJ

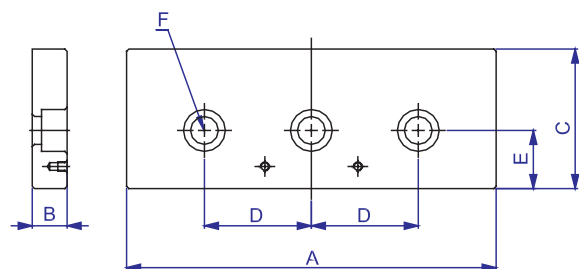

Model NO.	A	B	C	D	E	F (Bolt Size)
MPV125-OGJ	124	18	60	32	25	M8
MPV160-OGJ	159	21	60	46	25	M10
MPV200-OGJ	199	24	70	50	27.5	M10
MPV160-OGHJ	159	21	75	46	30	M10
MPV200-OGHJ	199	24	90	50	35	M10

※ MPV160-OGHJ & MPV200-OGHJ are only applied to Heightened Fixed Jaw & Heightened Movable Jaw

Unit : mm



Prism Jaw MPV125 / 160 / 200-SVJ

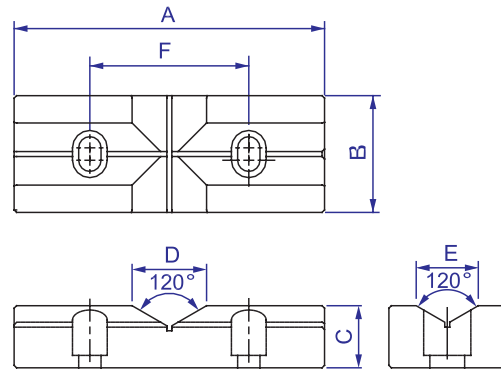

Model NO.	A	B	C	D	E	F	G (Bolt Size)
MPV125-SVJ	125	47	25	30	25	32	M8
MPV160-SVJ	160	62	30	30	30	46	M10
MPV200-SVJ	200	72	30	30	30	50	M10

Unit : mm

V Jaw MPV125 / 160 / 200-LVJ

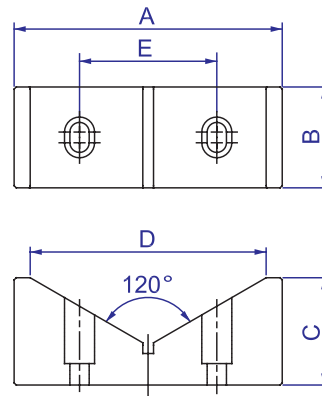

Model NO.	A	B	C	D	E	F (Bolt Size)
MPV125-LVJ	125	47	50	110	32	M8
MPV160-LVJ	160	62	55	130	46	M10
MPV200-LVJ	200	72	55	130	50	M10

Unit : mm

Ratchet Wrench





Hydraulic Machine Vise

HWA Series

Both slideways flame hardened to HRC56~60 can resist wear and maintain accuracy for long.

Alloy Steel Jaw which is flame hardened and precision ground ensures the accuracy.

Quick 3-step clamping position design can improve working efficiency.



It can do 360° revolution with the swivel base.

Hydra. Booster system can provide a steady clamping force against shocks and vibration during various operations since it fastens the workpiece resiliently with the aid of dish springs mounted inside.

Clamping force can be easily adjusted with the base line design as a guide.

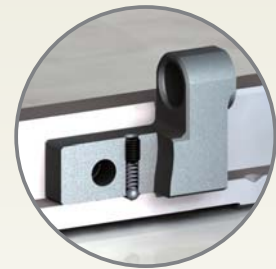

Auto-Positioning design.

Accuracy Inspection

	Inspection Items	Tolerance
1	<p>Parallelism : slideways to Vise bed</p>	0.01/100mm
2	<p>Squareness : between slideways and fixed jaw</p>	0.03/100mm
3	<p>Workpiece Lifting</p>	0.05mm



HWA-100 / 125 / 150 / 200

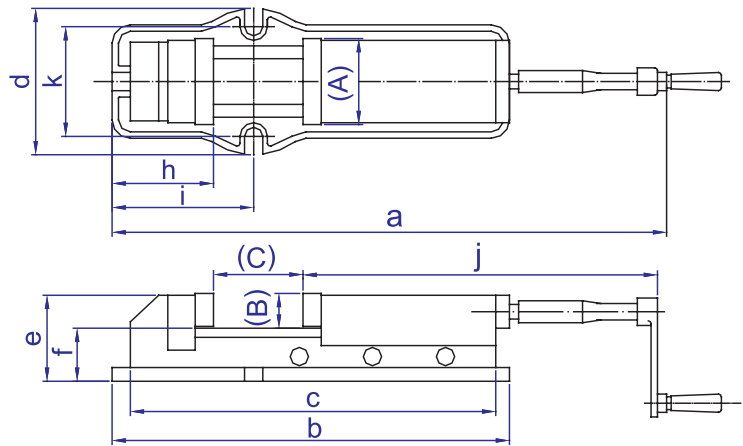
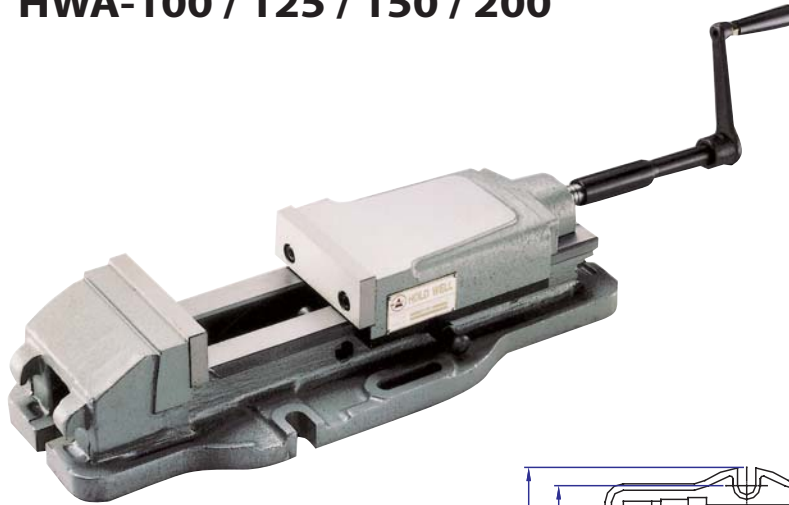

Model NO.	(A)	(B)	(C)	a	b	c	d	e	f	g	h	i	j	k	Max. Clamp. Force (kgf)	N.W. (kg)
HWA-100 (4")	100	36	0-170	525	435	395	160	94	58	78	101	155	263	120	2500	18
HWA-125 (5")	125	45	0-220	670	540	490	185	117	72	98	112	184	341	145	4000	32
HWA-150 (6")	150	51	0-300	800	610	570	240	133	82	116	127	205	380	200	5000	60
HWA-200 (8")	200	62	0-300	900	700	650	280	162	100	160	165	265	435	240	7000	90

Unit : mm

Standard Accessory



Handle Joint



Handle



HWC-100 / 125 / 150-2W / 3W / 4W

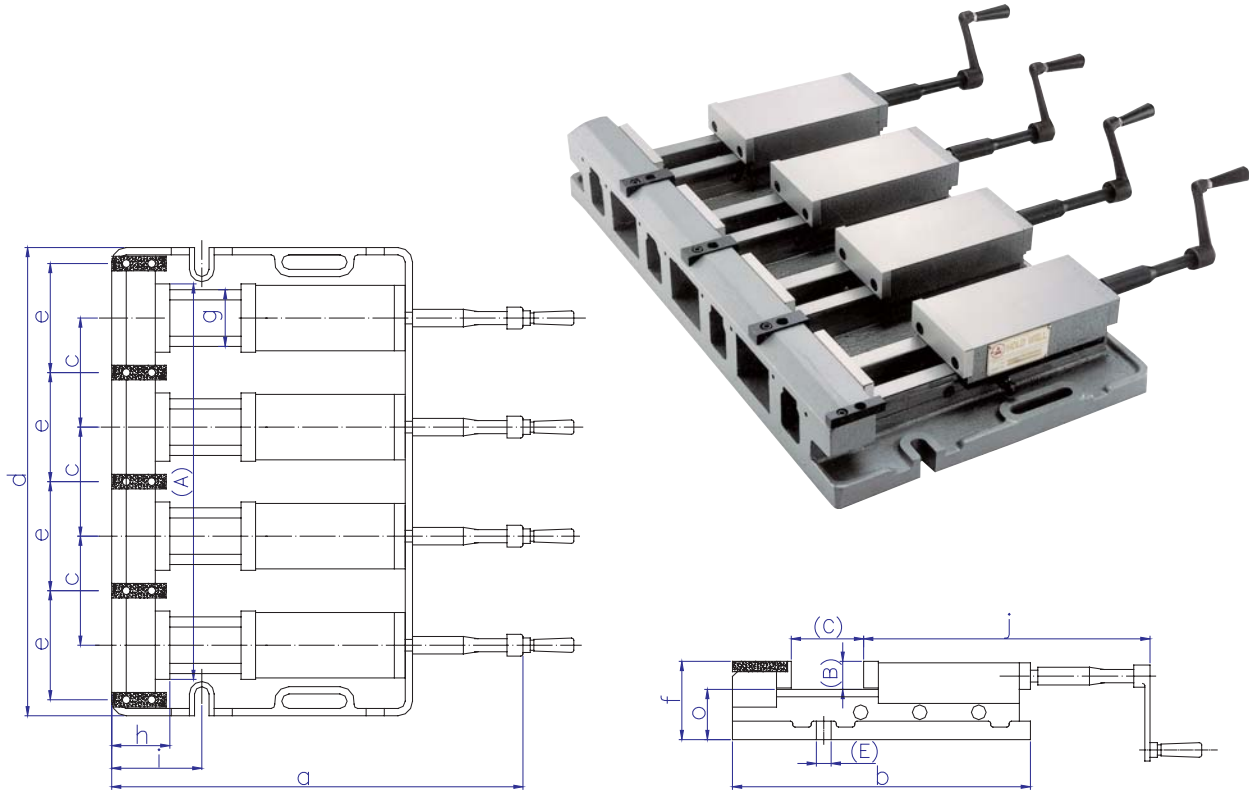

Model NO.	(A)	(B)	(C)	(E)	a	b	c±0.01	d	e±0.01	f	g	h	i	j	o	Max. Clamping Force (kgf)	N.W. (kg)
HWC-125-2W (5")	429	45	0-220	18	653	490	300	540	300	118	97	83	134	341	86	4000	90
HWC-150-2W (6")	484	51	0-300	18	807	610	330	550	330	139	116	128	210	380	98	5000	130
HWC-150-3W (6")	594	51	0-300	18	807	610	220	660	220	139	116	128	210	380	98	5000	175
HWC-100-4W (4")	599	36	0-170	16	519	400	165	695	165	107	78	70	112	263	72	2500	100
HWC-125-4W (5")	729	46	0-220	16	653	490	200	840	200	118	97	83	134	341	86	4000	180

Unit : mm

Standard Accessory



Handle Joint



Handle



Used with Pull-Down-Jaw & Mini Sine Bar, the angular accuracy can reach SECOND unit.

Efficient index auto-zeroing saves operating time and simplifies the operating process.

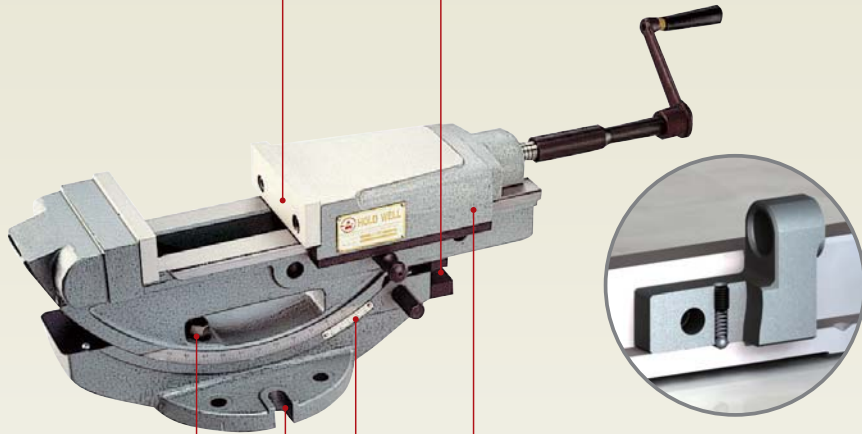

Tilting seat fixed by two locking screws provides high stability and no vibration during operations.

Auto-Positioning design.



It can do 360° revolution with the Swivel Base.

Tilting angle ranges from 0°~50°. Tilting degrees can be easily read from the indicator label.

Accuracy Inspection

	Inspection Items	Tolerance
1	<p>Parallelism : sideways to Vise bed</p>	0.05/100mm
2	<p>Squareness : between slideways and fixed jaw</p>	0.03/100mm



HWB-100 / 150

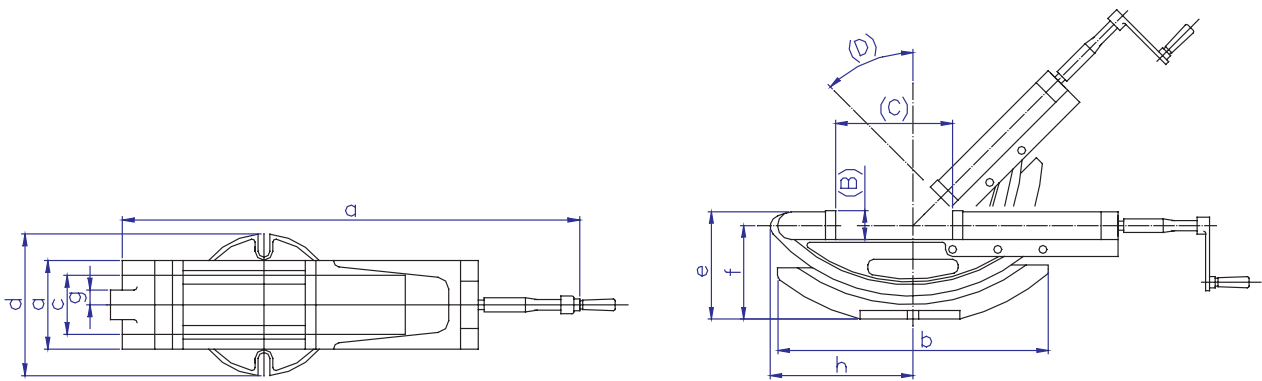
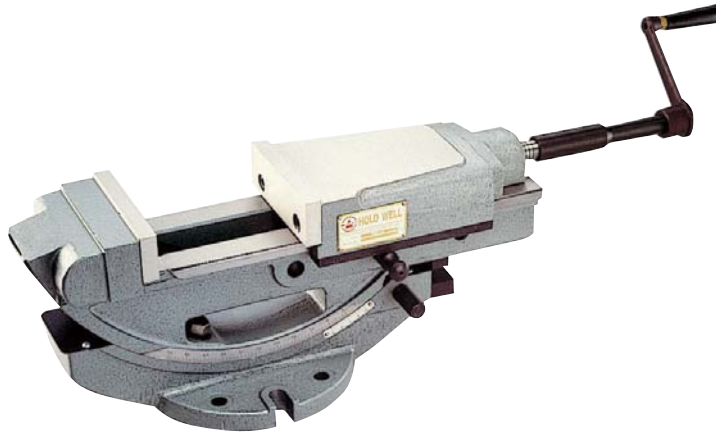

Model NO.	(A)	(B)	(C)	(D)	a	b	c	d	e	f	g	h	Max. Clamping Force (kgf)	N.W. (kg)
HWB-100 (4")	100	36	0-170	50°	505	325	65	160	177	141	80	184	2500	23
HWB-150 (6")	150	51	0-300	50°	775	410	95	240	237	186	100	240	5000	63

Unit : mm

Standard Accessory



Handle Joint



Handle



Can be combined with many sets together for the processing application. The tolerance of matched height is within $\pm 0.01\text{mm}$.

Both slideways are flame hardened and precision ground.

The specially-designed movable Jaw can hold down the workpiece and improve the processing accuracy.

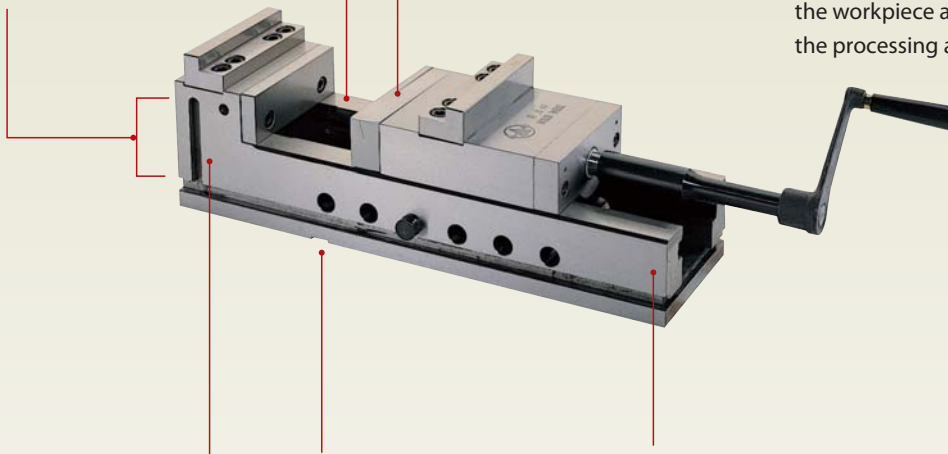

Vise body and fixed Jaw are mono-block casting. With tensile strength 65 kg/cm^2 , it is suitable for high-pressure processing without distortion and power-losing after long clamping.

The parallelism and squareness of slots beneath vise base are very precise. Vise can be quickly positioned and fixed on the machining tables.

All the surfaces of NC Vise are processed with high-frequency heat treatment. The tolerance of parallelism and squareness is within $\pm 0.01\text{ mm}$. It can be put by side.

Accuracy Inspection

Inspection Items		Tolerance
1	<p>Parallelism : slideways to Vise bed</p>	0.01/100mm
2	<p>Squareness : between slideways and fixed jaw</p>	0.02/100mm
3	<p>Workpiece Lifting</p>	0.02mm
4		A
		B
		C
		D
		E
		0.01mm



HWD-A130 / 150

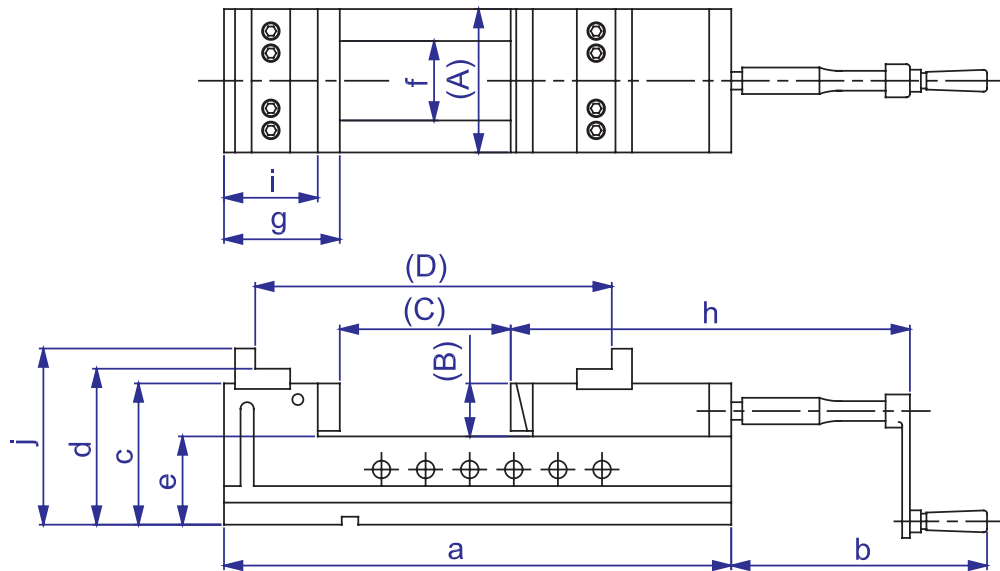

Model NO.	(A)	(B)	(C)	(D)	a	b	c	d	e	f	g	h	i	j	Max. Clamping Force (kgf)	N.W. (kg)
HWD-A130 (5")	130	49	0-205	205-300	460	207	128	145	80	72	87	334	72	161	4000	50
HWD-A150 (6")	156	53	0-284	284-460	554	207	143	159	90	80	100	339	83	173	4400	60

Unit : mm

Standard Accessory



Handle Joint



Handle

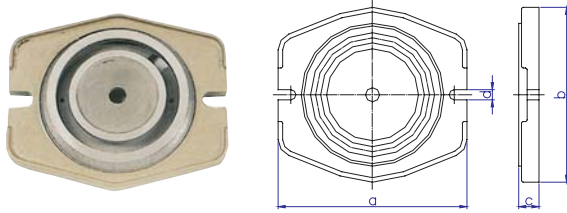

Swivel Base 100 / 125 / 150 / 200-S

Model NO.	a	b	c	d	N.W.(kg)
100-S	280	210	28	16	4
125-S	287	267	33	18	7
150-S	335	310	36	19	10
200-S	373	355	41	19	16

Unit : mm



Prism Jaw 100 / 125 / 150 / 200-VJ

It can clamp round-shaped workpiece

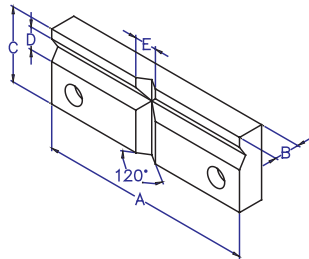

Model NO.	A	B	C	D	E
100-VJ	104	12	36	11	11
125-VJ	130	15	46	13	13
150-VJ	153	18	53	15	15
200-VJ	206	21	62	17	17

Unit : mm



Stripe Jaw 100 / 125 / 150 / 200-SJ

It can avoid vibration of workpiece

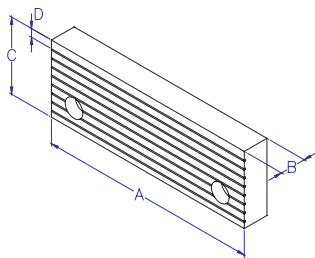

Model NO.	A	B	C	D
100-VJ	104	12	36	6
125-VJ	130	15	46	6
150-VJ	153	18	53	6
200-VJ	206	21	62	6

Unit : mm

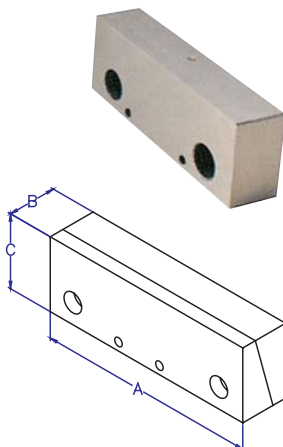

Pull-down Jaw 100 / 125 / 150 / 200-PJ

It can avoid workpiece lifting

Model NO.	A	B	C
100-PJ	104	30	33
125-PJ	130	32	33
150-PJ	153	34	33
200-PJ	206	36	33

Unit : mm



Both slideways flame hardened to HRC45 can resist wear and maintain accuracy for long.

The maximum clamping force can reach 6000 kgf.



Rigid material Vise body is made of ductile iron FCD60. High tensile strength and no distortion.

Down thrust "Semi-sphere Segment" mechanism can eliminates Jaw lifting and workpiece tilting.

Accuracy Inspection

	Inspection Items	Tolerance
1		Parallelism : slideways to Vise bed 0.015/100mm
2		Squareness : between slideways and fixed jaw 0.02/100mm
3		Workpiece Lifting 0.05mm

HWY-A125 / 150 / 200

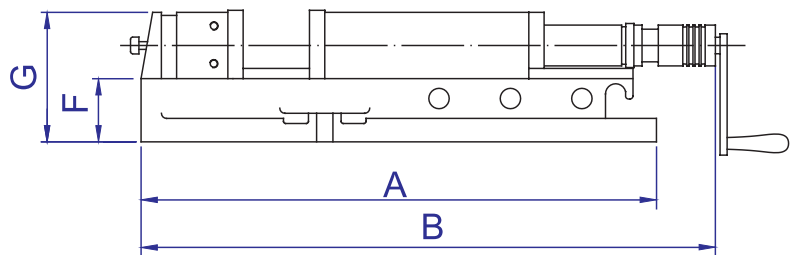
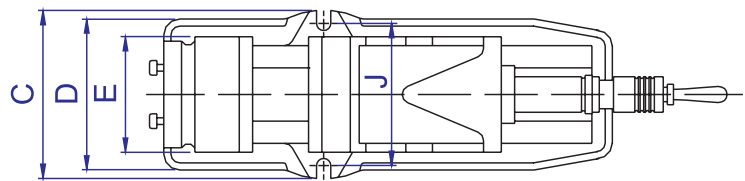

Model NO.	A	B		C	D	E	F	G	J	Jaw Opening	N.W. (kg)
		Min.	Max.								
HWY-A125	505	570	795	190	170	130	72	127	75	220	37
HWY-A150	605	625	935	240	210	160	82	140	101	310	55
HWY-A200	700	725	1035	280	240	200	100	163	115	310	93

Unit : mm

Standard Accessory



■ Screw



■ Handle



Accurate clamping-force setting can prevent any damage to workpiece from the improper pressure; the minimum setting unit is 100kgf.

The opening length can be set precisely and the minimum setting unit is 5mm. It can be applied for various quick workpiece clamping requirements.

Multiple protection procedure : emergency switch / beeper / fuse / liquid-leaking detector / IP65 water-proof design.

Fast-moving Jaw design. It moves at 10 mm/s.

Quick Pressure Booster system can produce the pressure from 0 to 4000 kgf within 5.5 seconds.

Manually-driven device design in case of power failure or emergency.

Modular controller. Easy maintenance.

Connection Function. It can remotely operated in connection with external controller. It can also parallel- connect several Auto Vises to clamp simultaneously or in turn.

- Electricity-driven vise can be used with only electricity and without any air & hydraulic equipment. No air pollution. It could be used in various environments: peopleless plant, cleanroom, seriously-polluted environment, vacuumlike condition.
- Can parallel-connect several vises either without or with external controller for simultaneous movement.
- Can be set through respective controller; the parameter of respective vise can be also set through external controller.
- Hierarchical Menu Interface. Easy operation and quick setting make the operators get familiar easily.
- The power device adopting DC24V greatly ensures the safety.
- It can be applied on processing with the robot arm.
- The operation temperature ranges from -20 °C to 70 °C.

※ Accuracy : please refer to MC Precision Power Vise

HWE-AMV160

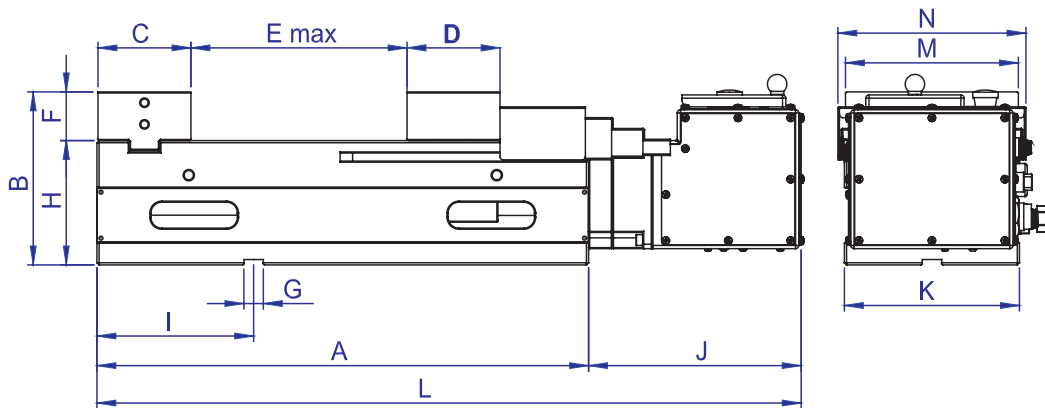

Model No.	A	B	C	D	E max	F	G	H	I	J	K	L	M	N	N.W. (kg)
HWE-AMV160	455	160	86	86	275	45	18	115	145	197	162	652	160	174	70

Voltage : AC110~115V or AC220~230V Hertz : 50 Hz or 60 Hz

Unit : mm

Standard Accessory



Eye Bolts



L-shaped wrench



Slide Cover



Positioning Block

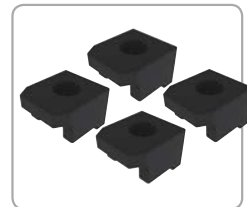

Clamps

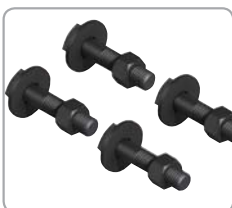

T-Nut & Screw

※ Optional Accessory

1. Jaw:
Please refer to the optional accessory
of MC Precision Power Vise

2. Electronic accessory :
Transformer : Input : AC 100-240V, 40A
Output : DC +24V
Transmission line