

BARON-MAX V Range High Performance Vertical Machining Centers

Massive Base Construction with 4 Box Ways guide ways in the Y-axis
And solid box ways in X and Z axes offering excellent rigidity

Model: V-1000 / V-1300 / V-1500



New generation V-Series with enhanced rigidity and cutting performance

- Fully enclosure with interlock sliding doors, integrated coolant wash gun & air guns
- 12/16 Kw high power spindle motor offers high torque output
- Spindle 10,000 rpm with spindle oil chiller to ensure long life and low heat growth.
- 24 Position Dual Arm Automatic Tool Changer.
- Pretension high precision C3 grade double nuts ball screws directly coupled to the servo motor on all models.
- Duplex angular contact bearings support both ends of all ball-screws,
- All axes laser calibrated & ballbar verified.
- One year parts and labor warranty and two years Siemens Control Warranty



Spindle speed up
to 12,000 rpm



24 Tools Swing
Arm type ATC



Heavy duty cutting
and high accuracy



High quality
surface finishing



Laser calibration and
Ball-bar analysis

Baron Max Cost Effective High Performance Vertical Machining Centers

The V Range VMC's Provides Heavy Duty 4 Box Ways Base, XYZ axes Hardened Box Ways for heavy duty with high accuracy



Baron Max V-1300

- X/Y/Z travel - 1300/750/610mm
- 12/16kW Spindle Motor
- 10,000rpm speed range (12,000 rpm opt)
- High rigidity 4 Box ways
- XYZ axes Box Ways for heavy cutting
- 24/24/20 m/min rapids
- 24 station Swing Arm type ATC
- BT40 spindle (CAT 40 Opt)

Baron Max V-1500

- X/Y/Z travel - 1500/750/610mm
- 12/16kW Spindle Motor
- 10,000rpm speed range (12,000 rpm opt)
- High rigidity 4 Box ways
- XYZ axes Box Ways for heavy cutting
- 24/24/20 m/min rapids
- 24 tool Swing Arm type ATC
- BT40 spindle (CAT 40 Opt)



Extra Rigid Machine Structures

BARON MAX V Range has a 24 tools Swing Arm high speed tool change with 2.0 sec tool to tool change time, standard on all models

A cartridge spindle is dynamically balanced for smooth operation and long life, Class P4 angular contact bearing for high rigidity, select a range of 40 taper from 10000 rpm or 12,000 rpm

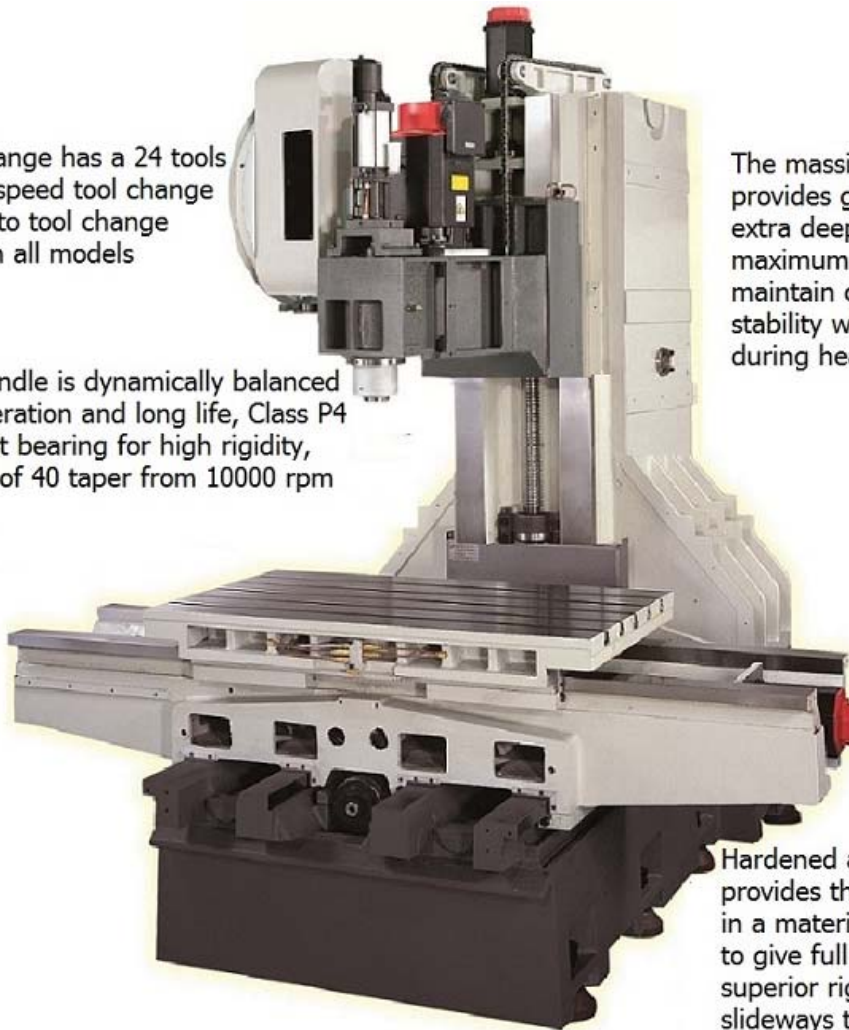

The massive cast iron column construction, provides greater dampening capability. the extra deep column is heavily ribbed for maximum lateral stiffness, designed to maintain consistent accuracy and thermal stability while withstand great forces required during heavy cutting

Hardened and ground box ways on XYZ axes provides the rigidity demand for heavy cutting in a material, Heavy duty four box ways bases to give full support of saddle which provides superior rigidity, Turcite-B anti-friction coating on all slideways to ensure maximum performance and wear

The Baron-Max V range was design with wide, precision hand-scraped, four-box guide ways in the Y-axis and wide box ways in the X and Z-axes to maximize machine rigidity

- 4 box way bed construction for heavy duty with high accuracy
- 12/16 Kw high power spindle motor offers high torque output
- Spindle oil chiller
- Pneumatic counter weight system with air tank provides excellent stability.
- Flood coolant system with programmable air blast
- High volume chip flushing system
- Screw type Auger conveyor
- Heat exchangers for control cabinets
- Rigid tapping

**Full range, Quality Assurance.....
100% Laser and Ball Bar Tested Before Shipping....**



Every machine is measured & calibrated by a Renishaw Laser and Ball-Bar analysis and undergoes a rigorous 50 hours of non-stop running before shipment. A certificate of accuracy is also included for each machine.

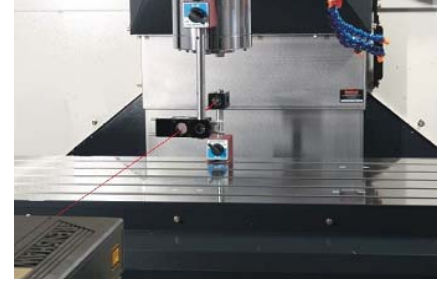

Inspection Standard	Positioning A	Repeatability R
ISO 10791 – 4	0.032	0.018
BaronMax V Range	± 0.01	± 0.005

JIS B 6338 show the same value as ISO standard L ≤ 1250 mm, P value of VDI 3441 is equivalent to A of ISO 10791 And Ps of VDI 3441 is equivalent to R of ISO 10791-4
All values shown above are inspecting for machine in good air conditioned environments

Tool shank & Pull stud

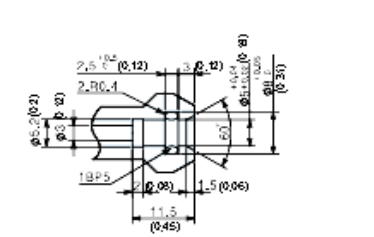
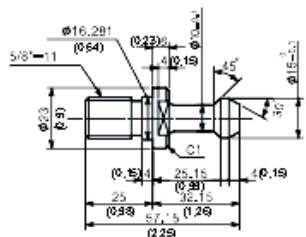
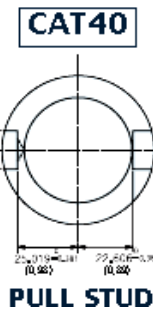
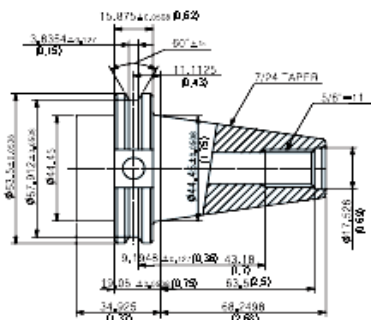
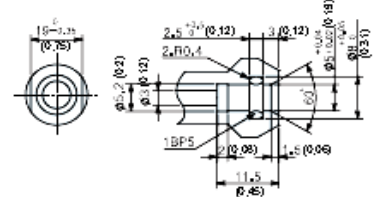
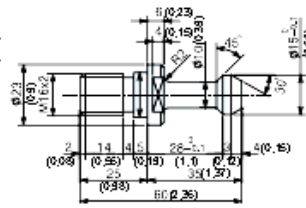
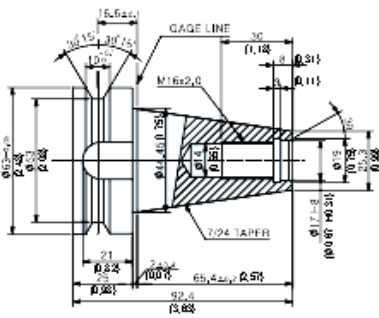

Product Features:

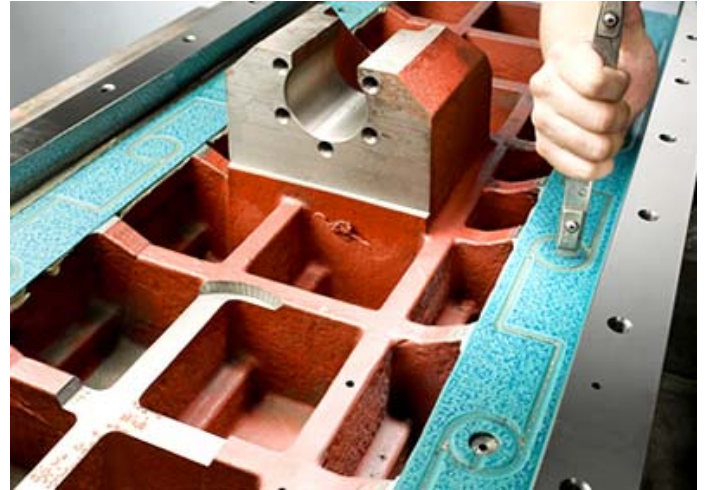

Mechanical accuracy is based on the flatness less than $5 \mu\text{m}$ in 1 M^2
High rigidity 4 Box Guide ways on base, X Y Z axes Hardened Box Ways



High rigid Cartridge Belt Drive Spindle



Largest and rigidity column



the ballscrews and linear ways are lubricated automatically by timer controlled oil injection



24 Tools Swing Arm type ATC



A screw type auger is provided as a standard feature



Double-anchored ballscrews with twin pre-loaded ball nut

Choice of controls:



Easy to Operate, Simpler Setups, Powerful CNC Functions Siemens Sinumerik 828D

- 10.4" Color TFT Display, Full QWERTY keyboard
- ShopMill conversational programming,
- Program GUIDE and ISO programming
- 80-bit NANO Floating Point Accuracy technology to ensure high speed accuracy
- 3D Solid graphics simulation
- Advance Surface technology for high speed 3D surfaces
- Simplified Tool and Workpiece Management
- USB, Compact Flash Card, Ethernet on the Front Panel + RS-232C
- It's simple — easy-to-setup, easy-to-use

SINUMERIK 828D also meets the demands of high sophisticated mold & die applications



CNC 8055i MC

Ideal for large production lines and for unitary parts applications



- New Conversational Digitizing Cycles makes Digitizing extremely quick and easy
- 11" high resolution LCD Color Monitor
- 255 Tool Length, Diameter & Wear Offset
- High-Speed Algorithms
- Ethernet Capability, USB port standard
- Powerful Interactive Graphic Interface for easy programming - No Prior CNC knowledge required.
- Memory (512MB) & DNC communication
- Two ways of programming: Icon Based Conversational and G Code (On-line)
- Solid & Tool Path Graphic Simulation with zoom and part rotation
- Advanced Look Ahead 100 Block
- High-Level Programming
- On board PLC
- High-Speed Algorithms

The controller options consist of user friendly systems from Siemens & Fagor ideally suited to the first time user, Fanuc is also available if preferred.

Specification

		V-1000	V-1300	V-1500
MACHINING ENVELOPE				
Axis Travel	X	1020 mm	1300 mm	1500 mm
	Y	600 mm	750 mm	750 mm
	Z	610 mm	610 mm	610 mm
Spindle nose to table (mm)		100~710	100~750	100~750
Spindle center to column		640 mm	760 mm	760 mm
Table				
Table size		1100 * 600	1400 * 600	1700 * 600
Table loading capacity		1000 kg	1500 kg	1500 kg
T-slot configuration		18 mm x 5T	18 mm x 5T	18 mm x 5T
Spindle				
Taper		BT# 40(STD.), or DIN-69871A (Opt.), BT#50 (opt.)- V-1500		
CNC Control System		Siemens 828d, or FAGOR 8055i FL MC		
Spindle speed		10,000 (Siemens Std), 8000 rpm(FAGOR Std), 12000 (Option),		
Coolant through spindle		Available. Complies with DIN 69871 from B tool holder		
Main motor (con/30 min KW)		12/16 KW (Standard), 22/30		
Axes Transmission				
X Y Z Rapid feed		X-Y axes : 24 m/min, Z axis: 20 m/min		
X Y Z feed rate		10 m/min		
Feed Motor torque (XYZ) Nm		16 / 16 / 16 Nm		
Accuracy				
Positioning		±0.005 (±0.0002")		
Positioning repeatability		±0.003 mm (±0.0001")		
Automatic Toolchanger				
Number of Tools (ATC)		24 tools Dual Arm Type.		
Tool selection		By address code, Random / bi-directional rotation		
Pull stud		MAS 403-P40T (45°),CT40 (45°) or DIN 69872 B (45°)		
Max. Tool diameter		Ø 80 mm		
Max. Tool weight		8 Kgs		
Max. Tool length		300 mm (12")		
Tool change time (tool to tool)		2 sec for Arm Type		
Coolant pump motor		3/4 HP		
Air required		kg/cm (85 psi)		
Machine weight (Approx.)		5800 Kg	7300 Kg	7500 Kg

* Specifications are subject to change without notice

Standard Accessories:

- Fagor 8055i FL / Siemens 828D controllers available
- High speed 10,000 RPM spindle
- Powerful 12/16 Kw high torque spindle motor
- 24-station automatic dual arm tool changer
- Telescopic way covers for X, Y and Z axis
- Fully enclosed splash guard with interlock
- Auger conveyor
- Rigid tapping
- Coolant system
- Coolant gun
- Air gun
- Halogen work light
- Automatic lubrication system
- Portable MPG
- Leveling pads & bolts for installation
- Tool box & kits
- Lamp of cycle finish & alarm
- Heat exchanger for the electrical cabinet
- CE Norms

Optional Accessories:

- 12,000 rpm Spindle speed.
- Built in coolant through spindle with 20 bar pressure
- Extra cost for CTS/70 bar with separate CTS tank
- Tool offset Probe
- Work piece measuring probe
- Air conditioner for the electrical cabinet
- Wash down system
- Chain type chip conveyor with bucket
- 4th Axis preparation.
- Φ 8", 10" 12" and 14" 4th axis Rotary Tables
- Φ 8" and 10" 5th Axis Tilting Rotary Tables
- Oil skimmer
- Safety module for Fagor/Siemens controller
- EMC for Fagor/Siemens controller
- Transformer
- X-Y-Z axes linear scale